

# BELLOWS CONNECTOR EXPANSION JOINT

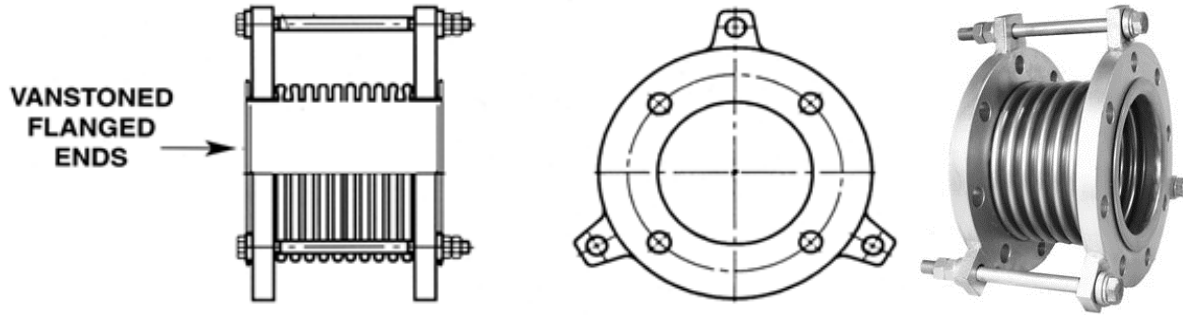

### OPERATING CONDITIONS

150° ..... 225 psi  
 212° ..... 190 psi  
 480° ..... 110 psi  
 \*Maximum Temperature

Side 1 Type .....150# VS FLG  
 Side 2 Type .....150# VS FLG  
 Bellows ..... 304 S/S  
 End Fittings ..... C/S

Dimensions		Movements			Physicals			Weight	Product No.
Pipe Size	Length	Axial Comp	Axial Ext	Lateral	Thrust Area	Spring Rate Ax	Spring Rate Lat		
in	in	in	in	in	in <sup>2</sup>	lbs/in	lbs/in	lbs	
2	6	0.9	0.2	0.25	5	516	4370	12	BCON0200
2.5	6	0.9	0.2	0.25	9	498	4370	16	BCON0250
3	6	0.9	0.2	0.25	11	349	6070	18	BCON0300
4	6	1	0.2	0.25	19	803	19700	28	BCON0400
5	6	1	0.2	0.25	29	987	59200	34	BCON0500
6	6	1	0.2	0.25	39	1171	77500	43	BCON0600
8	6	1	0.2	0.25	64	1222	78600	63	BCON0800
10	8	1.4	0.2	0.375	97	1659	67900	93	BCON1000
12	8	1.4	0.2	0.375	139	1815	233000	120	BCON1200
14	8	1.4	0.2	0.375	183	3960	508364	145	BCON1400

 <b>"Flexible Piping Solutions"</b>	Customer Name:	NOTES:  
	Project Name:	
	Contractor:	
PRINT CERTIFICATION:  Certified Correct As Of: _____  By: _____	The Bellows Connectors are kept in stock.	