

2315 W Hubbard
Chicago, IL 60612

P: 800-533-1024
f: 312-421-6327

**MSLFG
FOOD GRADE
FLEXIBLE CONNECTOR
SANITARY F/F/R**

- SILOFLEX* silicone rubber liner and integral gasket
- 300 series stainless steel convoluted bellows and wire braid
- Operating temperature of: -60° F to +300° F
- Working pressure of 150 PSIG, 300 PSIG available
- Interior surface is sanitary with no areas of entrapment

For food & beverage applications:
(Sanitary Flex/Flo/R Model #1511)

- Food grade FDA SILOFLEX* liner and integral gasket (sanitary braid cover available)
- 150# ANSI drilled T304 stainless steel flanged ends

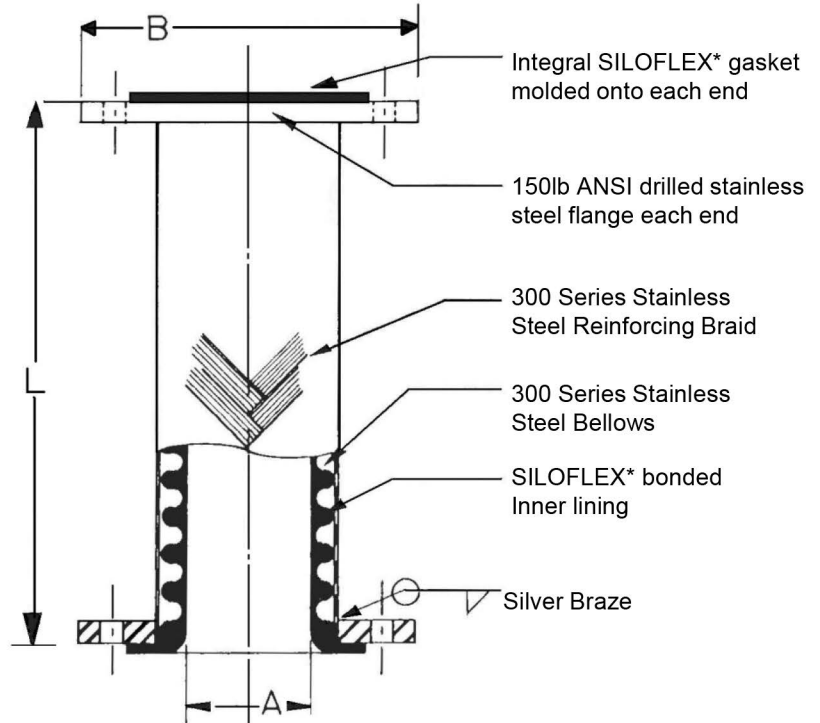

NOMINAL PIPE SIZE A	FLANGE DIAMETER B	FLEX/FLO/R* LENGTH L			
		6	12	18	24
1 ½	5	6	12	18	
2	6	6	12	18	
2 ½	7	6	12	18	
3	7 ½	6	12	18	24
4	9	6	12	18	24
5	10	6	12	18	24
6	11	6	12	18	24
8	13 ½	6	12	18	24

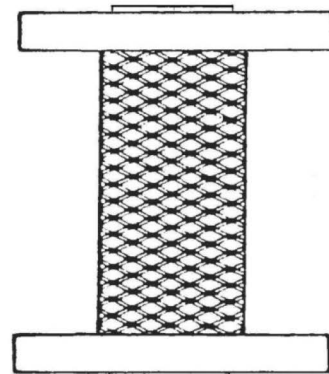

Job _____

Contractor _____

Engineer _____

Representative _____

Order No. _____ Date _____

Submitted by _____

Approved by _____ Date _____

Tag _____

**Flexible Connector
Type F/F/R (Flex/Flo/R)
SILOFLEX* Lined**